

Linear slot diffuser, 25mm slot (SLD)

Linear slot diffusers (SLD) are suitable for use in ceiling or sidewall applications handling supply or exhaust air, providing horizontal or vertical air patterns and are available in 1800mm lengths with 1 to 8 slot configurations as standard. Each slot includes full length adjustable air pattern blades to

suit directional requirements. A continuous line appearance is achieved by butting sections together with alignment strips. SLD diffusers are solidly manufactured from welded aluminium extrusions and fully finished end caps.

Standard finishers are:

Diffuser – stove enamel or powder coat in RAL 9010 white.
Blade – matt black.
Other colours available at additional cost.

Options to standard products are:

One piece, fully welded, mitred corner sections.
Widths in excess of 8 slot.
Variations to diffuser outer flanges.
Blanking plates.

Dimensions

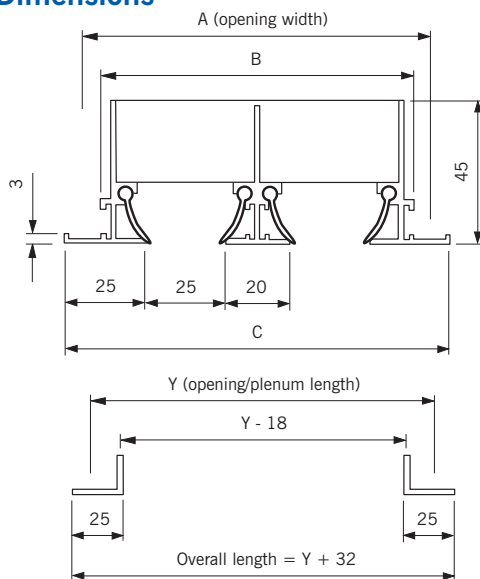

No of Slots	Dimensions		
	A	B	C
1	63	53	75
2	108	98	120
3	153	143	165
4	198	188	210
5	243	233	255
6	288	278	300
7	333	323	345
8	378	368	390

Fixing methods

FMK: For use with conventional first fix plenum box (model PLB), clamping to a suspension bracket by concealed screw (standard).

FMO: For use with second fix plenum box(model PLO), hanging diffuser by side brackets (special).

Selection

Linear slot diffuser, 25mm slot (SLD)

VERTICAL SUPPLY PERFORMANCE				
Volume m ³ /s/m	No. of slots	Throw metres	NR	Pa
0.02	1	0.6	-	3
0.04	1	1.7	21	11
	2	0.6	-	3
0.06	1	2.8	31	25
	2	1.3	-	7
	4	0.7	-	3
0.08	2	2.0	-	12
	3	1.2	-	5
	4	0.7	-	3
0.10	2	2.7	28	19
	3	1.7	-	8
	4	1.1	-	5
0.14	3	2.7	27	17
	4	1.9	22	8
0.18	4	2.8	25	14
0.20	4	3.2	31	17
0.22	4	3.6	33	20
0.24	4	4.0	35	25

SIDEWALL SUPPLY PERFORMANCE				
Volume m ³ /s/m	No. of slots	Throw metres	NR	Pa
0.02	1	0.8 - 1.5	-	-
0.03	1	1.0 - 1.9	13	-
	2	0.7 - 1.5	-	-
0.04	1	1.2 - 2.4	21	11
	2	0.9 - 1.9	-	-
0.05	1	1.4 - 2.9	26	15
	2	1.1 - 2.3	10	4
	3	1.0 - 2.0	-	-
0.06	1	1.7 - 3.4	31	22
	2	1.3 - 2.6	15	6
	3	1.1 - 2.3	-	-
0.07	1	1.9 - 3.8	34	37
	2	1.5 - 3.0	18	8
	3	1.3 - 2.5	9	4
0.08	1	2.1 - 4.3	38	40
	2	1.7 - 3.4	22	11
	3	1.4 - 2.8	12	5
0.09	1	2.4 - 4.8	41	50
	2	1.8 - 3.8	25	14
	3	1.5 - 3.0	15	6
0.10	2	2.0 - 4.1	27	16
	3	1.7 - 3.3	18	7
0.11	3	1.8 - 3.5	20	9
0.12	3	2.0 - 3.8	22	11
0.13	3	2.1 - 4.0	24	13
0.14	3	2.2 - 4.3	26	15

Performance data general

Performance selection data tables are provided for Linear Slot Diffusers mounted horizontally in a flat ceiling or a sidewall application in both supply or return air mode. Twin, curved, control blades per slot provide directional air flow across a ceiling or vertically. Tabulated data is based upon isothermal air conditions.

Throw data

All throw data is based upon a 1.0 metre active length of Slot Diffuser, at a ceiling height of 2.7 metres, with minimum and maximum figures relating to an air terminal air velocity of 0.50m/s and 0.25m/s respectively. For other lengths please use the correction factors indicated in the relevant table. Each additional 0.5m. in excess of the 2.7m. ceiling height will reduce the throw by 0.5m.

Sound levels

All NR figures shown are based on a 1.0 metre active length of Slot Diffuser and a room absorption factor of 8db re 10-12 watts. For other lengths please use the correction factors indicated in the relevant table. These sound levels relate only to the Slot Diffuser, and do not include additional noise generation from plenum boxes, spigots or dampers.

Pressure drop

Pressure drop figures refer only to the Slot Diffusers and not to plenum boxes, spigots or dampers.

Vertical projection

This data is based upon a non-isothermal vertical free jet with a 10 degree C heating temperature differential and a decay of jet velocity to a terminal air velocity of 0m/s.

Diffuser length correction factors

Diffuser Length	0.5m	1.0m	1.5m	2.0m	2.5m	3.0m
Multiply throw by	0.85	1	1.06	1.12	1.17	1.21
Add to NR level	-3	0	+2	+2	+3	+3

Performance data

Linear slot diffuser, 25mm slot (SLD)

CEILING SUPPLY PERFORMANCE				
Volume m ³ /s/m	No. of slots	Throw metres	NR	Pa
0.02	1	1.4-1.6	-	-
0.03	1	2.0-3.5	13	5
	2	1.5-2.4	-	-
0.04	1	2.5-4.1	21	11
	2	2.0-3.0	-	-
0.05	1	3.1-5.2	26	15
	2	2.4-3.7	10	4
	3	1.8-3.1	-	-
0.06	1	3.6-5.9	31	22
	2	2.9-4.3	15	6
	3	2.2-3.7	5	-
	4	1.9-3.4	-	-
0.07	2	3.3-5.0	18	8
	3	2.5-4.2	9	4
	4	2.2-3.8	-	-
0.08	2	3.7-5.6	22	1
	3	2.9-4.7	12	5
	4	2.5-4.1	7	-
0.9	2	4.1-6.2	25	14
	3	3.2-5.2	15	6
	4	2.8-4.4	10	-
0.10	2	4.5-6.8	27	16
	3	3.5-5.7	18	7
	4	3.1-4.7	13	-
	5	2.8-4.4	8	-
0.11	2	4.9-7.4	30	19
	3	3.9-6.2	20	9
0.12	3	4.2-6.7	22	11
	4	3.7-5.3	18	5
	5	3.2-5.1	13	-
	6	2.9-4.7	9	-
0.13	3	4.6-7.2	24	13
0.14	4	4.3-5.8	21	7
	5	3.6-5.8	17	5
	6	3.3-5.3	13	-
	7	3.0-4.9	14	-
0.16	4	4.9-6.3	25	9
	5	4.1-6.5	20	6
	6	3.7-5.9	16	4
	7	3.4-5.5	18	-
	8	3.2-5.1	10	-
0.18	4	5.4-6.8	28	12
	5	4.5-7.1	23	7
	6	4.1-6.5	19	5
	7	3.8-6.0	16	4
	8	3.6-5.6	13	-
0.20	5	4.9-7.7	26	9
	6	4.5-7.0	22	6
	7	4.2-6.6	19	5
	8	4.0-6.2	16	4

CEILING SUPPLY PERFORMANCE CONTINUED				
Volume m ³ /s/m	No. of slots	Throw metres	NR	Pa
0.22	5	5.3-8.3	28	11
	6	4.9-7.6	24	8
	7	4.6-7.1	21	6
	8	4.3-6.7	18	4
0.24	6	5.3-8.1	26	9
	7	4.9-7.6	23	7
	8	4.7-7.2	21	5
0.25	6	5.7-8.6	28	11
	7	5.3-8.1	25	8
	8	5.0-7.7	23	6
0.28	6	6.1-9.2	30	13
	7	5.7-8.6	27	9
	8	5.4-8.2	24	7
0.30	7	6.0-9.1	29	11
	8	5.7-8.7	26	8
0.32	7	6.4-9.6	30	12
	8	6.1-9.2	28	9

RETURN AIR PERFORMANCE			
Volume m ³ /s/m	No. of slots	NR	Pa
0.02	1	-	2
	1	13	5
0.03	1	16	9
	2	-	2
0.04	1	21	13
	2	-	4
	3	-	2
0.05	1	26	19
	2	-	5
	3	-	3
0.06	1	33	34
	2	17	9
	3	-	4
	4	-	2
0.08	1	38	53
	2	22	14
	3	13	6
	4	-	4
0.10	2	32	33
	3	23	14
	4	18	8
	5	13	5
	2	40	58
0.15	3	30	26
	4	25	14
	5	21	9
	6	16	6
	4	32	24
	5	27	16
0.20	6	21	11
	4	35	33
	5	31	21
	6	27	14
0.26	7	24	11
	8	21	6
	4	35	33
	5	31	21
0.30	6	27	14
	7	24	11
	8	21	6