

## Steel exhaust air valves (SEV)

**Steel exhaust air valves (SEV)** are suitable for use with all types of ventilating systems and offer an alternative low cost valve where noise level, although important, is not critical.

Adjustment of the airflow is achieved by rotating the inner cone to the desired setting and is secured by means of a single lock nut.

Valves are available in 6 sizes to suit duct diameters of 80, 100, 125, 150, 160 and 200mm.

The mounting ring is suitable for connecting to conventional ducting or for grouting into a wall and should be positioned to ensure that the front rim is flush with the finished wall face.

The air valve has a quarter turn bayonet type fastening which secures it firmly in place in the mounting ring.

SEV valves are manufactured from steel spinnings, protected by a gloss white stove enamelled paint. The outer body

is fitted with a gasket to form an airtight seal with the mounting ring. The mounting ring being made from plated steel.

### Dimensions

Nom. Size	A	B	C	Weight (g)
80	115	61	75	150
100	137	75	75	195
125	161	100	95	310
150	202	120	95	400
160	212	130	95	470
200	248	157	120	660

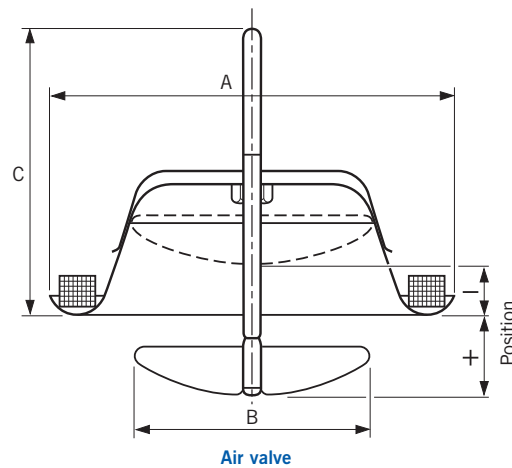

Nom. Size A	B	C	Weight (g)
80	108	30	45
100	130	30	50
125	155	30	65
150	178	30	75
160	190	30	100
200	236	30	140

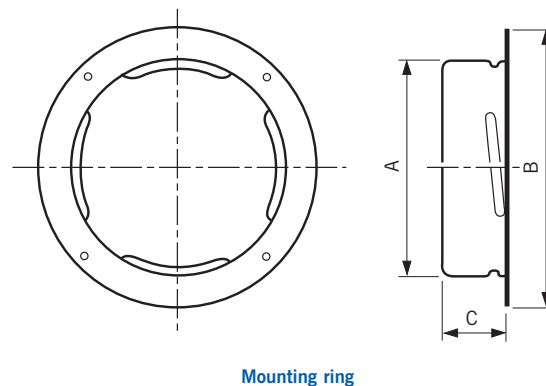

Performance data

Steel exhaust air valves (SEV)

G02

Steel exhaust air valves (SEV)

