

Type TLA

Tower louvres (TLA & TLB)

Tower louvres (TLA and TLB) are rigidly constructed from aluminium extrusions, and offer a high degree of weather protection in combination with a large free area (approx 50%), making them excellent air intake or exhaust units for ventilation through the roof. The tower louvres are made in two types. TLA, the smaller unit, is assembled and dispatched as a one-piece structure, max.

perimeter 4 metres, max. height 0.675 metres.

TLB supplied and shipped in sections, has no limitation in size apart from that dictated by economy, stability and practicality.

The louvres and sills are 1.6mm extruded aluminium.

The roof is fabricated from 14swg aluminium sheet, and the roof is of 25mm bonded lining for acoustic insulation.

The bird screen is galvanised wire 25 x 12mm weldmesh (vermin mesh is available).

TLB supporting frame is made from angle iron, painted with a zinc rich primer.

Mill finish is standard.

Special finishes require the louvre to be in sections which can be handled in the painting system.

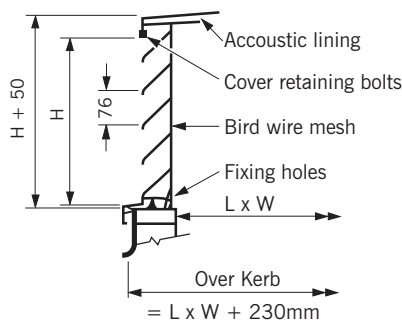

TLA

Tower Louvres are made to customer order.

Note: The height must increase in 76mm increments.

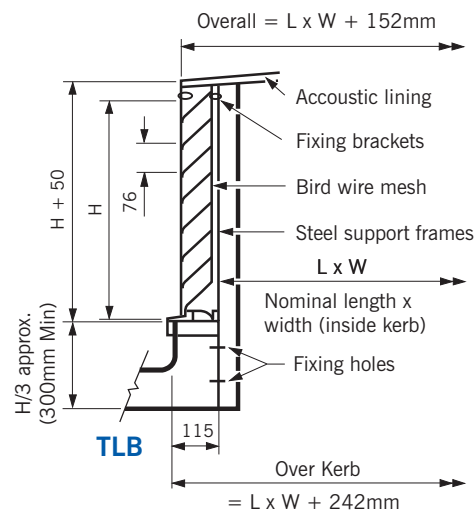

TLB

Type TLB

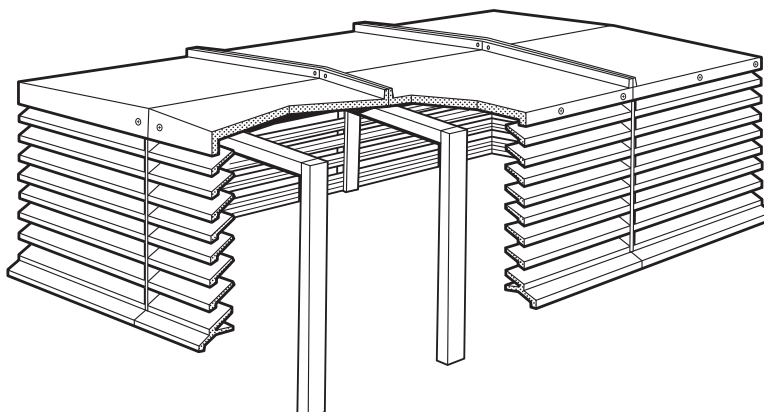

Performance data

Tower louvres (TLA & TLB)

The free area of a Tower Louvre should be equal to or slightly greater than the area of the roof opening. A smaller free area will increase the resistance, a larger free area gives little advantage.

To minimise rain or snow carry over

on intake requires a low jet velocity. The carry over velocity is approximately 2.25 metres per second. The accompanying table shows the free area in square metres of standard height Tower Louvre for values of length plus

width (L & W). However, when used for exhaust the limiting factor is generally resistance to air flow. The graph shows the relationship between pressure drop and roof opening velocity.

